

# All SS Utility Gauges

2.5" (63mm) Model **23S** (1/4"NPT)

4.0" (100mm) Model **46S** (1/4"NPT) **47S** (1/2"NPT)



## FILLABLE, 1/4 or 1/2 inch NPT. One-Piece Welded Case/Stem

- 304 SS Crimped-on Bezel
- Blow Out Relief; Fill Lever-Type Grommet
- Polycarbonate Lens
- White Aluminium Dial (Black Printing)
- Black Aluminium Pointer
- Stainless Steel Movement, Dampened
- AISI 316 Stainless Steel Wetted Parts
- Pulsation Restrictor Screw (Removable)

Accuracy: 1.6%

### RAGE

As Below (psi/bar/x100KPa)

### MOUNTING TYPES

- No Code:** Bottom Connection  
**CB:** Center Back Connection  
**LB:** Lower Back Connection  
**FP:** Front Flange for Panel Mounting  
**C:** C-Clamp Fixing for Panel Mounting  
**R:** Rear Flange for Wall Mounting



Model: 46S-6K  
To order other models by part #, See Below

### RANGE SELECTION

<u>Range Code</u>	<u>Range (psi)</u>	<u>Range Code</u>	<u>Range (psi)</u>		
<b>V30</b>	Vacuum 30"Hg-0	<b>160</b>	0-160		
<b>R315</b>	Receiver 3-15	<b>200</b>	0-200		
<b>C15</b>	Compound 30"Hg+15	<b>300</b>	0-300		
<b>C30</b>	Compound 30"Hg+30	<b>400</b>	0-400		
<b>C60</b>	Compound 30"Hg+60	<b>600</b>	0-600		
<b>C100</b>	Compound 30"Hg+100	<b>800</b>	0-800		
<b>C160</b>	Compound 30"Hg+160	<b>1K</b>	0-1,000		
<b>C200</b>	Compound 30"Hg+200	<b>1500</b>	0-1,500		
<b>C300</b>	Compound 30"Hg+300	<b>2K</b>	0-2,000		
<b>15</b>	0-15	<b>3K</b>	0-3,000		
<b>30</b>	0-30	<b>5K</b>	0-5,000		
<b>60</b>	0-60	<b>6K</b>	0-6,000	<b>15K</b>	15,000
<b>100</b>	0-100	<b>10K</b>	0-10,000	<b>20K</b>	20,000

Additional Code Suffix for dual scale ranges: (KGM2 = Kgm2/ PSI) (NH3 = Ammonia Temp Scale)

### HOW TO ORDER BY PART NUMBER:

- 1 Model Number
- 2 Choose Pressure Range (code)
- 3 Choose Mounting Type (code)
- 4 If special requirements are needed, add description
- 5 Liquid filling, if desired: **GF=Glycerin**, **SF=Silicone**, **FF=Fluorolube**

### FOR EXAMPLE 46S-6K

4 inh All SS Utility Gauge,  
1/4inch NPT  
0-6,000 psi  
Bottom Connection  
PSI Only Single Scale

Model	Dial Range Code	Mounting Type	Non-Standard Requirements	Filling Type
<b>46S</b>	<b>6K</b>		PSI Only	None

We manufacture a wide range of instruments to customer's special requirements  
We shall be pleased to discuss and advise on your specifications.

Specifications and dimensions given in this leaflet represent the state of engineering at the time of printing.

Engineering modifications may take place without prior notice.

# All SS Utility Gauges

2.5" Model 23S (1/4"NPT)

4.0" Model 46S (1/4"NPT)      Model 47S (1/2"NPT)

Rear Flange Wall Mounting

Direct Mounting (Standard)

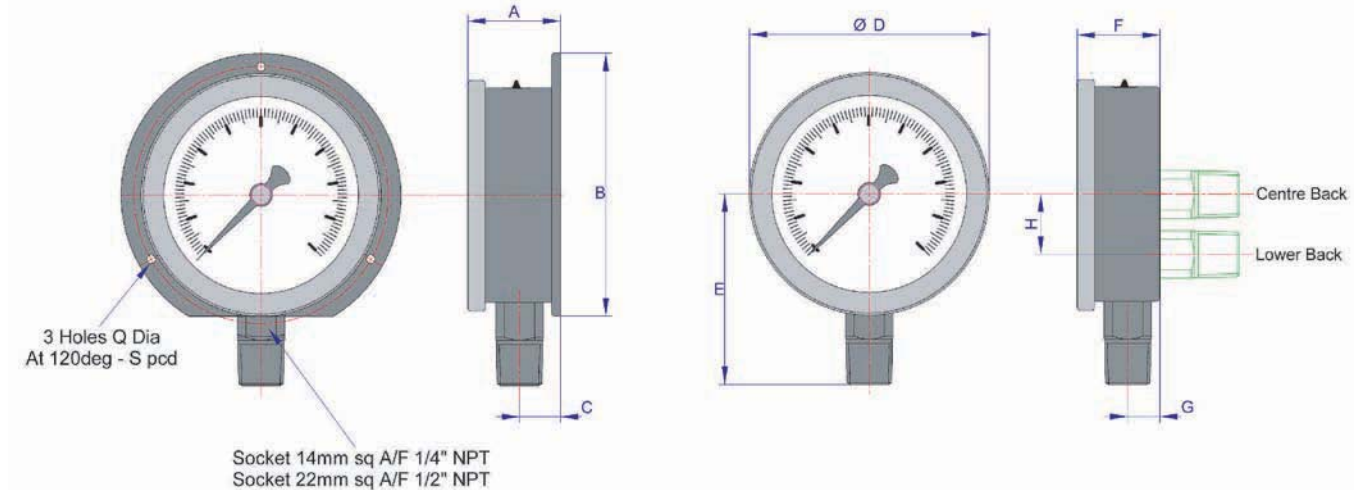

Front Flange Panel Mounting

Clamp Fixing Panel Mounting

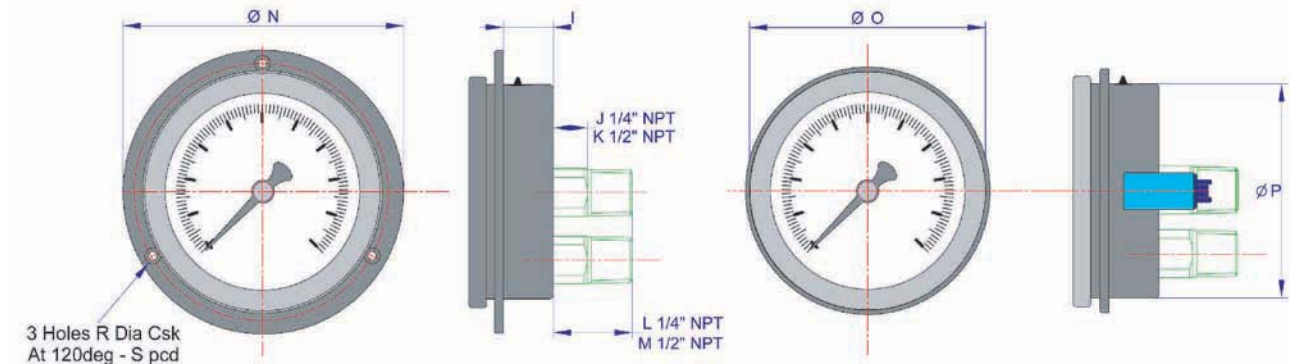

	A	B	C	D	E	F	G	H	I	J	K	L	M	N	O	P	Q	R	S	Cut Out
	Dims																			
(23S)	63mm 2.5in			67.3 2.65	56 2.20	30.5 1.20	10.6 0.42	18 0.71	19.5 0.77					85.2 3.35	67 2.64	62 2.44	3.8 0.15	3.8 0.15	75 2.95	66 2.60
(46S/47S)	100mm 4in			109 4.29	78.5 2.97	33.5 1.32	0.82 12.2	18 0.71	20.8 0.82					132.5 5.21	110 4.33	98.8 3.89	6 0.24	6 0.24	118 4.65	106 4.17

Warning: Before use, please consult our recommendation regarding selection and installation or consult ASME B40.1. Copies available on request.



**STEWARTS-USA**

6786 Tipperary  
Houston, TX 77061 USA  
Phone: 713-643-1022  
Fax: 713-643-2855  
Toll Free: 800-901-1316  
www.StewartsUSA.com